

Installation Manual

MCS-100 Remote Control Motorcycle Alarm



WWW.ULTRASTARTERS.COM

Technical Support 866-698-5872 ext 0

Support@ultrastarters.com

SECTION 1: SYSTEM LAYOUT

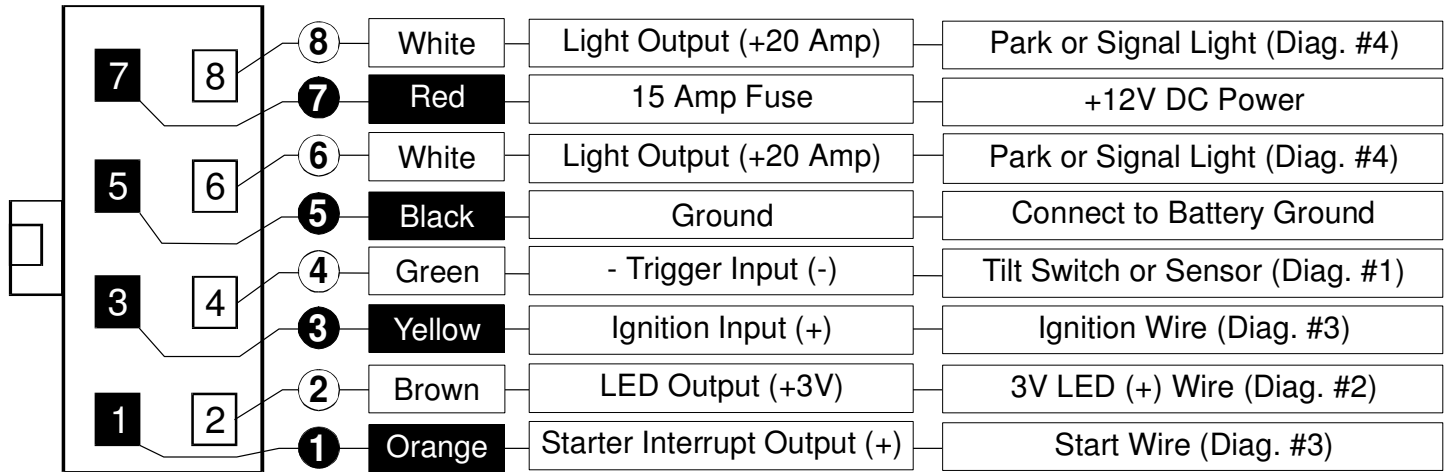

SECTION 2: SYSTEM CONNECTION

Diagram #1: Tilt Switch or External Sensor Connection

You can connect any external trigger devices. Make sure negative trigger output of external device is connected to Negative Trigger Input Wire (Green #4).

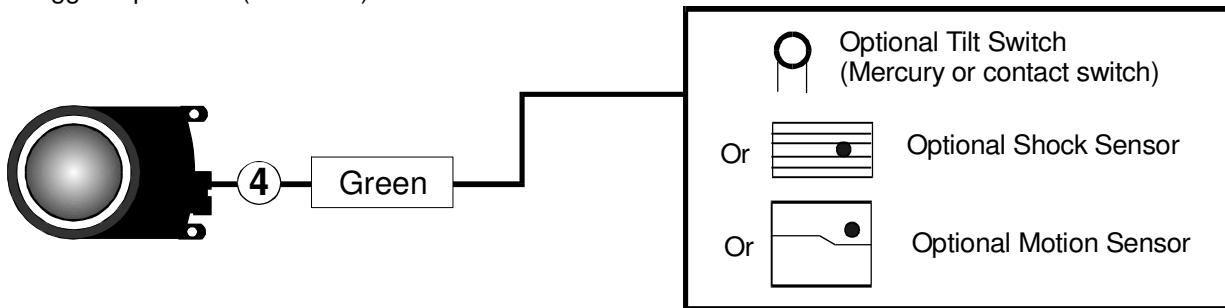

Diagram #2: LED Connection

1. Locate a stock replacement part of motorcycle. Drill 1/4" hole, pull wires through and push LED.
2. Connect wires as shown.

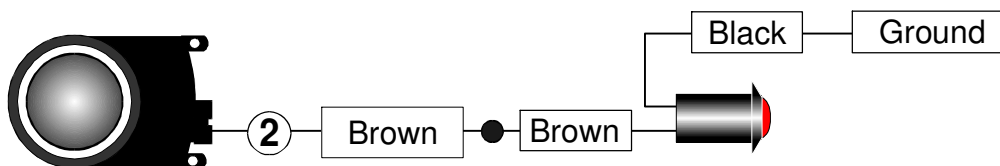

Diagram #3: Starter Interrupt and Ignition Connection

1. Locate the Starter wire.

- Use 30/40 Amp SPDT relay to connect as shown. Connect the Starter Interrupt output (Orange) wire to pin 86 of the relay. Connect pin 30 of the relay to the Motor side of the Starter wire. Connect pin 87a of the relay to the switch side of the Starter wire.
- Locate the Ignition wire.
- Connect the Switched ignition (yellow) wire and 85 of the Starter Interrupt relay to the Ignition wire.

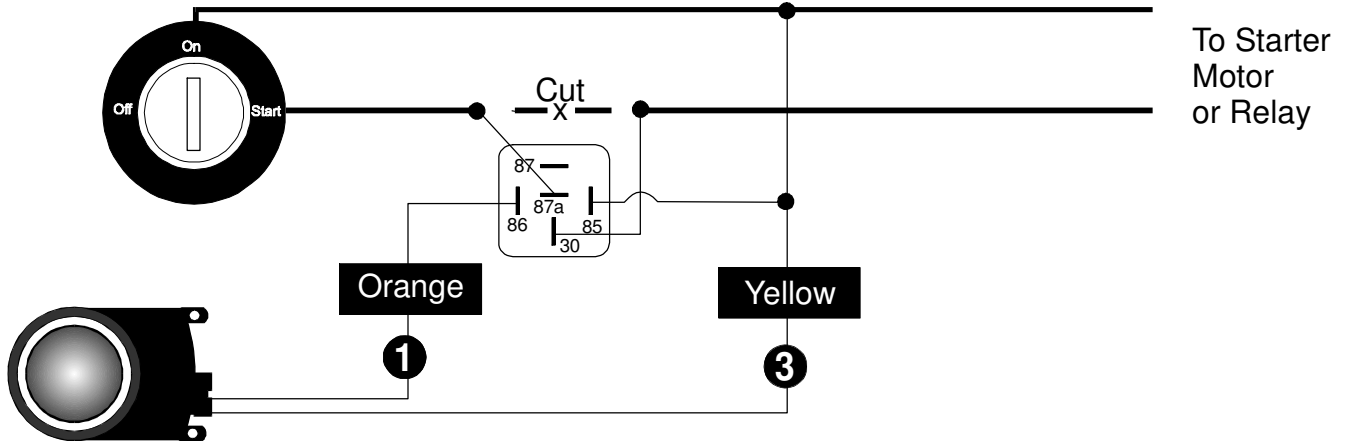
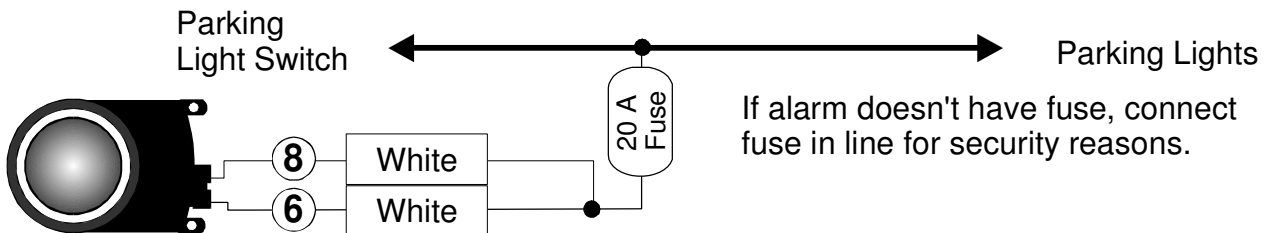

Diagram #4: Parking Light Connection

- Locate the parking light wire or signal wire that switches from Ground to +12V when turning on the parking lights or signal lights. (usually near the parking light switch)
- Connect the parking light output wire (White) to the parking light wire of the motorcycle. We have two parking light output wires for two separate (left & right) controls for the parking lights. (If there is only one control for the parking lights, then connect both white wires to the same parking light.)
- If the parking light wire switches from +12V to Ground when turning on parking lights, use a 20/30A SPDT relay to invert the control signal polarity.

Positive Controlled Parking Lights



Negative Controlled Parking Lights

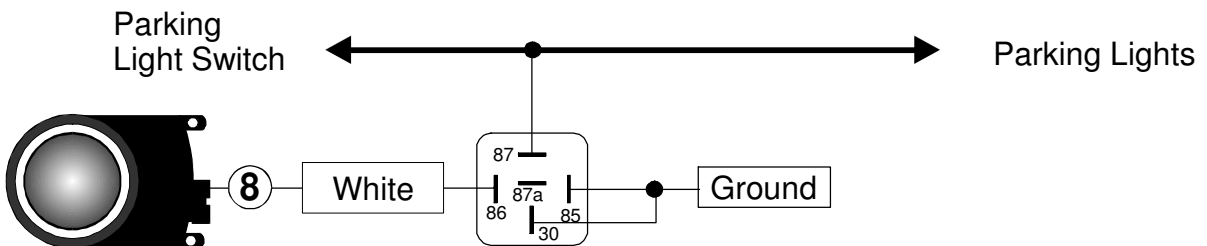

SECTION 3: SYSTEM OPERATION

The MCS-100 is very sophisticated, but the operation is simple. Your two button RF transmitter is easy to use for arm, disarm, personal protection, and programming the system for many custom functions.

3.1 Remote System Arm (On)

- ◇ Press and release RF transmitter button #1.
- ◇ One siren chirp sound and a light flash verify the operation.
- ◇ If you hear four chirp sounds, the MCS-100 has detected a faulty sensor.

3.2 Remote System Disarm (Off)

- ◇ Press and release RF transmitter button #1.
- ◇ Two siren chirps and two light flashes verify this operation.

Note: If you hear three chirp sounds, the system has been triggered and the alarm was activated while you were away from the vehicle. Please refer to following chart. This diagnostic report will turn off when ignition switch is turned on.

| Diagnostic Report | Audible - Chirp | Visual - LED |
|----------------------------------------------------------|-----------------|----------------|
| Shock Sensor | 3 chirps | Double Flashes |
| Optional Input Trigger (Mercury Switch, Microwave & etc) | 3 chirps | Rapid Flashes |

3.3 Personal Protection Alarm (EMERGENCY PANIC)

- ◇ Press and hold down RF transmitter button #1 for approximately three seconds.
- ◇ Personal Panic alarm is activated and siren sounds and lights flash for one (1) minute.
- ◇ Press and release any RF transmitter button to cancel the panic alarm.

3.4 Motorcycle Finder Mode

- ◇ Press and hold down RF transmitter button #3 (#1+#2) for approximately three seconds.
- ◇ Lights flash for one (1) minute.
- ◇ Press and release any RF transmitter button to cancel the Motorcycle finder mode.

SECTION 4: PROGRAMMABLE FEATURES

| Programming Function | Programming Method | Chirp | Light |
|------------------------------------|---------------------------------------------------------------------------------------------------------------------------------------------------------------------------|-------|-------|
| Code Program Method 1 | Power On. Within 3 seconds, press button #1 of new transmitter. Press button #1 of 2 nd transmitter and then press button #1 of 3 rd transmitter. | 1 | 1 |
| Code Program Method 2 (4.1) | Turn Ignition On/Off 5 times. Press button #1 of new transmitter. Press button #1 of 2 nd transmitter and then press button #1 of 3 rd transmitter. | 1 | 1 |
| Permanent Siren Chirp Disable | Turn Ignition on. Press button #2 for 5 seconds | None | 1 |
| Permanent Siren Chirp Enable (4.2) | | 2 | 2 |
| One Time Soft Chirp (4.3) | Press #2 before other function buttons. | | |
| Emergency Disarm (4.4) | Turn Ignition On/Off 4 times. Alarm will disarm. | 2 | 2 |
| Passive Mode | Turn Ignition on. Press button #3 (#3 = #1 + #2) for 5 seconds. | 1 | 1 |
| Active Mode (4.5) | | 2 | 2 |

| | | | |
|-------------------------------------------------------------|---------------------------------------------------------------------------------------------|--------|--------|
| Shock Sensor Disable Shock Sensor Enable (4.6) | Turn ignition on. Within 10 seconds, press button #1, #2, #3, #1 in succession. (#3=#1+#2) | 1 2 | 1 2 |
| Valet Mode On Valet Mode Off (4.7) | Turn Ignition on. Within 10 seconds, press button #2, #3, #2, #3 in succession. (#3=#1+#2) | 1 2 | 1 2 |
| Audible Warning Sound Off Audible Warning Sound On (4.8) | Turn Ignition on. Within 10 seconds, press button #1, #3, #2, #1 in succession. (#3=#1+ #2) | 1 2 | 1 2 |
| Siren Output Tone Selection (4.9) | Turn Ignition on. Within 10 seconds, press button #1, #2, #1, #2 in succession. (#3=#1+#2) | | |
| Shock Sensitivity Level Selection (4.10) | Turn Ignition on. Within 10 seconds, press button #1, #3, #1, #3 in succession. (#3=#1+#2) | 1 | 1 |

4.1 Permanent Reprogrammable Factory Code (Code Pre-Programmed By Factory)

When the Dealer installs the unit he programs your unique code which is in permanent memory. Any Authorized Dealer can add a new or an additional pre-coded transmitter and delete an existing code from memory.

To program a new code:

- Turn the ignition key on and off five (5) times.
- CODE CHANGE MODE is confirmed with one chirp sound and one parking light flash
- Within 3 seconds, PRESS BUTTON #1. One chirp and one parking light flash will confirm the acceptance of new code. This operation will erase all previous codes.
- Within 3 seconds, PRESS BUTTON #1 of 2nd transmitter. One chirp and one parking light flash will confirm the acceptance of second code.
- Within 3 seconds, PRESS BUTTON #1 of 3rd transmitter. Once chirp and one parking light flash will confirm the acceptance of third code.
- Code program will exit when 3 seconds is passed, when ignition is turned off or when all three codes are programmed.

Note: Module will accept three different transmitters.

4.2 Permanent Siren Chirp Enable/Disable (Factory default setting: Siren Chirp Enable)

Siren chirp can be permanently enabled and disabled from your remote transmitter.

For PERMANENT SIREN CHIRP DISABLE:

- Turn the ignition key to the on position.
- Within ten (10) seconds, PRESS BUTTON #2 for a five (5) seconds.
- Siren chirp disable is confirmed with one parking light flash.

For PERMANENT SIREN CHIRP ENABLE:

- Turn the ignition key to the on position.
- Within ten (10) seconds, PRESS BUTTON #2 for a five (5) seconds.
- Siren chirp enable is confirmed with two chirp sounds and two parking light flashes.

4.3 One Time Soft Chirp

Arm/Disarm chirp can be temporarily softened from your remote transmitter.

For TEMPORARY SOFT CHIRP (One Time Soft Chirp):

- PRESS BUTTON #2 before pressing button #1 for desired operation.

Example: To arm the system with soft chirp sound, press button #2 first. Then press button #1.

4.4 Emergency Disarm

The emergency disarm is activated through the ignition key switch and means that the system can be disarmed without remote.

To activate the *EMERGENCY DISARM*:

- While the system is triggered, turn the ignition key on and off four (4) times within ten (10) seconds.
- The operation is confirmed with two siren chirp sounds and two parking light flashes.

NOTE: *In passive mode, if passive armed after disarming by emergency disarm, there is entry delay of 10 seconds before triggering by shock or external trigger. This mode can be used to operate the system if you lose the transmitter. Once the system is armed or disarmed by a remote, the entry delay will be cancelled automatically.*

4.5 Passive/Active Mode (Factory Default Setting: Active Mode)

Passive mode means that the system automatically arms and interrupts the starter thirty seconds after the ignition key is turned off (This assumes that starter interrupt is installed). Passive mode is sometimes referred to as Automatic System Activation.

Active mode means that the system will not engage until you manually turn it on by pressing the remote button #1. Active mode is sometimes referred to as Manual System Activation.

To program *PASSIVE MODE*:

- Turn the ignition key to the on position.
- Within ten (10) seconds, PRESS BUTTONS #3 for 5 seconds.
- The passive mode is confirmed with one chirp sound and one parking light flash.

NOTE: *While in passive mode, the system has CONTINUOUS ARMING. CONTINUOUS ARMING means that the system will arm thirty seconds after each disarm. In passive mode, the system can be MANUALLY ARMED anytime during the thirty second automatic locking cycle by pressing remote button #1.*

To program *ACTIVE MODE*:

- Turn the ignition key to the on position.
- Within ten (10) seconds, PRESS BUTTONS #3 for 5 seconds.
- The active mode is confirmed with two chirp sounds and two parking light flashes.

4.6 Shock Sensor Disable/Enable (Factory Default Setting: Shock Sensor Enable)

The Shock Sensor Disable means that the on-board body shock sensor can be eliminated through your transmitter at any time it is desired or necessary.

To program *SHOCK SENSOR DISABLE*:

- Turn the ignition key to the on position.
- Within ten (10) seconds PRESS BUTTONS # 1, #2, #3, #1 in succession. (#3=#1+#2)
- The shock sensor disable is confirmed with one chirp sound and one parking light flash.

To program *SHOCK SENSOR ENABLE*:

- Turn the ignition key to the on position.
- Within ten (10) seconds PRESS BUTTONS # 1, #2, #3, #1 in succession. (#3=#1+#2)
- The shock sensor enable is confirmed with two chirp sounds and two parking light flashes.

4.7 Valet Mode

The Valet Mode is activated through the ignition key switch and means that all normal system functions are turned off. This feature is useful when valet parking, refueling, or servicing your motorcycle.

To activate the VALET MODE:

- Turn the ignition key to the on position.
- Within ten (10) seconds PRESS BUTTONS #2, #3, #2, #3 in succession. (#3=#1+#2)
- The valet mode is confirmed with one chirp sound and one parking light flash.

To deactivate the VALET MODE:

- Turn the ignition key to the on position.
- Within ten (10) seconds PRESS BUTTONS #2, #3, #2, #3 in succession. (#3=#1+#2)
- The operation is confirmed with two chirp sounds and two parking light flashes.

4.8 Audible Warning Sound (Factory Default Setting: Audible Warning Sound On)

Audible Warning Sound can be permanently enabled and disabled from your remote transmitter.

To deactivate the AUDIBLE WARNING SOUND:

- Turn the ignition key to the on position.
- Within ten (10) seconds PRESS BUTTONS #1, #3, #2, #1 in succession. (#3=#1+#2)
- The operation is confirmed with one chirp sound and one parking light flash.

To active the AUDIBLE WARNING SOUND:

- Turn the ignition key to the on position.
- Within ten (10) seconds PRESS BUTTONS #1, #3, #2, #1 in succession. (#3=#1+#2)
- The operation is confirmed with two chirp sounds and two parking light flashes.

4.9 Siren Output Tone Selection

Your MCS-100 is equipped with 6 tone programmable siren. You can select or deselect each tone by your transmitter if desired. At the same time, you can also determine the sequence of tones.

To enter the SIREN OUTPUT TONE SELECTION MODE:

1. Turn the ignition key to the on position.
2. Within ten (10) seconds PRESS BUTTONS #1, #2, #1, #2 in succession.
3. Each of six tones will be on for 5 seconds.
4. When you hear the tone you desire, press remote button #1. This tone will be your first sequence tone.
5. Repeat step 4 for your 2nd, 3rd, 4th, 5th, and 6th tone.
6. You may select only 1 tone or any number of tones between 1 to 6.
7. You may also choose not to select any tones. This will deactivate the siren completely.
8. This program mode will exit upon ignition off or when all six tones are selected in sequence you desire.



Turn Ignition
On



Press #1-2-1-2
in succession



Each tone is
on for 5 seconds.



Press #1 to
select the tone

4.10 Shock Sensitivity Level Selection

Your MCS-100 is equipped with programmable dual stage shock sensor. You can change sensitivity of shock sensor from your transmitter. You can also delete shock sensor by selecting lowest sensitivity level.

To enter the SHOCK SENSITIVITY LEVEL SELECTION MODE:

1. Turn the ignition key to the on position.
2. Within ten (10) seconds PRESS BUTTONS #1, #3, #1, #3 in succession. (#3=#1+#2)
3. The operation is confirmed with one chirp sound and one parking light flash.
4. Press button #1 of your transmitter to increase the shock sensor sensitivity.
5. If you want to increase more than one level of sensitivity, press and hold button #1 of your transmitter. You will hear 1 chirp sound every 1 seconds. At the maximum setting, you will hear continuous chirp sounds.
6. Press button #2 of your transmitter to decrease the shock sensor sensitivity.
7. If you want to decrease more than one level of sensitivity, press and hold button #2 of your transmitter. You will hear 2 chirp sounds every 1 seconds. At the minimum setting, you will hear continuous chirp sounds.
8. This program mode will exit upon ignition off.

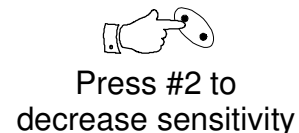
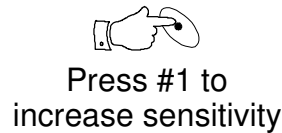
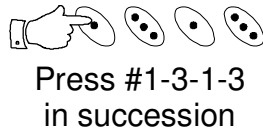

SECTION 5: TRANSMITTER BATTERY REPLACEMENT INSTRUCTIONS

Recommended Battery: +12V GP23A

1. Remove the screw from the back of the transmitter.
2. Remove front cover, remove old battery carefully.
3. Replace with fresh new battery and close front cover.
4. Press any button, check for light flash from LED. (If no LED flash, change polarity of battery)

NOTE: normal battery life is approximately two years, but varies depending on usage. For optimum performance and RF range, replace the battery at least once a year.

